

# M1160A

## Stepper Motor Driver Specification

### Overview

The M1160A is a high-performance stepper motor driver which applies accurate current controlling technology. It is suitable for 2-phase and 4-phase hybrid stepper motor below 6A, such as 110, 86 and so on. Due to the adoption of the advanced anti-noise sound control method, it can significantly reduce the noise and vibration during operation. It uses full current PWM control method, and shows stable operation, low noise, low vibration and low temperature rise of motor. There are 16 kinds of microstep of M1160A. The maximum step number of M1160A is 51200 steps/rev (microstep is 1/256 ). Its current range 0.38A-6A, and its output current has 16 stalls, and the current resolution ratio is about 0.4A. M1160A has automatic semi-flow, over-voltage, under voltage and over-current protection function. The driver is the AC power supply, the operating voltage range should be 80VAC-110VAC.

### Applications

It can be applied in a variety of automation equipment and instruments, such as labeling machine, cutting machine, packing machine, drawing machine, engraving machine, CNC machine and so on. It always performs well when it is used in equipment which requires for low-vibration, low-noise, high-precision and high-velocity.

### Current selection

Current	SW1	SW2	SW3	SW4
0.38A	0	0	0	0
0.75A	0	0	0	1
1.13A	0	0	1	0
1.50A	0	0	1	1
1.88A	0	1	0	0
2.25A	0	1	0	1
2.63A	0	1	1	0
3.00A	0	1	1	1
3.38A	1	0	0	0
3.75A	1	0	0	1
4.13A	1	0	1	0
4.50A	1	0	1	1
4.88A	1	1	0	0

5.25A	1	1	0	1
5.63A	1	1	1	0
6.00A	1	1	1	1

### Microstep selection

Pulse/Rev	SW7	SW8	SW9	SW10
1	0	0	0	0
2	0	0	0	1
4	0	0	1	0
5	0	0	1	1
6	0	1	0	0
8	0	1	0	1
10	0	1	1	0
16	0	1	1	1
18	1	0	0	0
20	1	0	0	1
32	1	0	1	0
40	1	0	1	1
50	1	1	0	0
64	1	1	0	1
128	1	1	1	0
256	1	1	1	1

Remark: 0=ON, 1=OFF

### Driver functions descriptions

Driver function	Operating instructions
Output current setting	Users can set the driver output current by SW1-SW4 four switches. The setting of the specific output current, please refer to the instructions of the driver panel figure.
Microstep setting	Users can set the driver Microstep by the SW7-SW10 four switches. The setting of the specific Microstep subdivision, please refer to the instructions of the driver panel figure.
Automatic half current function	Users can set the driver half flow function by SW5. "OFF" indicates the quiescent current is set to half of the dynamic current, that is to say, 0.5 seconds after the cessation of the pulse, current reduce to about half automatically. "ON" indicates the quiescent current and the dynamic current are the same. User can set SW5 to "OFF", in order to reduce motor and driver heating and improve reliability.

Signal interfaces	PUL+ and PUL- are the positive and negative side of control pulse signal; DIR+ and DIR- are the positive and negative side of direction signal; ENA+ and ENA- are the positive and negative side of enable signal.
Motor interfaces	A+ and A- are connected to a phase winding of motor; B+ and B- are connected to another phase winding of motor. If you need to backward, one of the phase windings can be reversed.
Power interfaces	It uses AC power supply. Recommended operating voltage is 80VAC-110VAC, and power consumption should be greater than 350W.
Indicator lights	There are two indicator lights. Power indicator is green. When the driver power on, the green light will always be lit. Fault indicator is red, when there is over-voltage or over-current fault, the red light will always be lit; after the driver fault is cleared, if re-power the red light will be off.
Installation instructions	Driver dimensions:158 × 100 × 59mm, please refer to dimensions diagram. Please leave 10CM space for heat dissipation. During installation, it should be close to the metal cabinet for heat dissipation.

### Signal interface details:

The internal interface circuits of the driver are isolated by the opt coupler signals, R in the figure is an external current limiting resistor. The connection is differential. And it has a good anti-jamming performance.

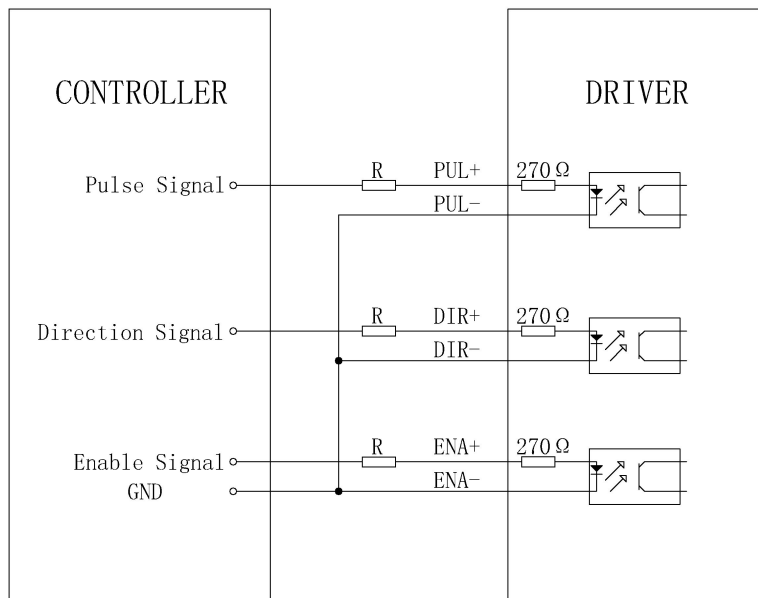

common cathode connection

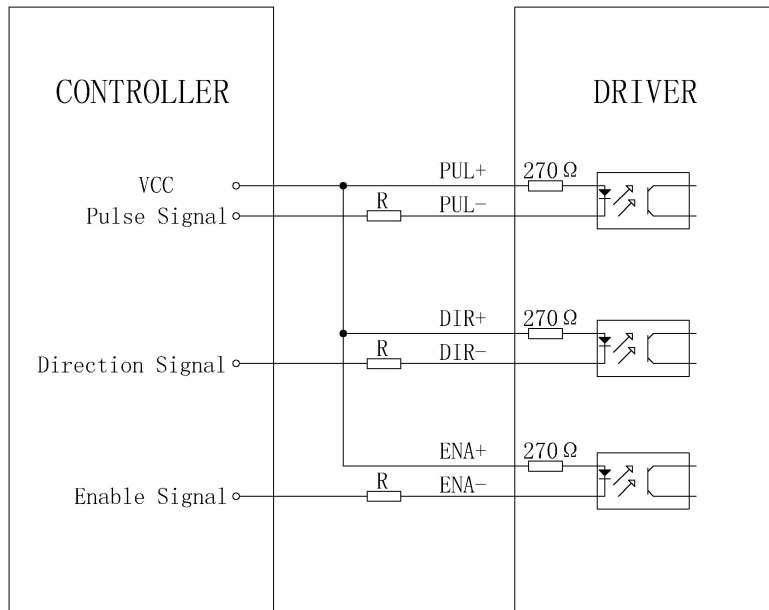

common anode connection

### Control signal and external interface:

Signal amplitudes	External current limiting resistor R
5V	Without R
12V	680 Ω
24V	1.8K Ω

### Common indicator

Phenomenon	Reason	Solution
The red indicator is on.	1. A short circuit of motor wires.	Inspect or change wires
	2. The external voltage is over or low than the driver's working voltage.	Adjust the voltage to a reasonable rang
	3. Unknown reason	Return the goods

Outline and installation size (unit: mm)

